

## Join Us on the Air!



- Sunday 14.263 mHz at 2000Z
- Tuesday 3805 kHz at 8pm CST
- Thursday 3805 kHz at 8pm CST
- Friday (West Coast) 3895 kHz at 10pm CST
- Sunday 10m AM 29.050 mHz at Noon CST
- 1<sup>st</sup> Wednesday AM 3880 kHz at 8pm CST

Sunday for Technical, Buy, Sell & Swap  
Tues., Thurs., Fri., & Sunday for Ragchew

## Inside This Issue

Collins HF-80 Product Line - Feature	1
From the Editors' Desk	2
Dayton & Dallas—Yes the Big D is ON!	2
Service Line- 30L-1 Meter Calibration	3
Election Update	14
In the Shack of AA9TT	15
From the President	16

Visit the CCA Website  
[www.collinsradio.org](http://www.collinsradio.org)

See our new features.  
You can also renew your membership on line via our website and the PayPal link.

## In the News

- CCA to Hold Dallas Ham-Com Event in 2011
- Read all about it—Dayton Hamvention Coming
- CCA has 2 New Board Members

## The Rockwell Collins HF-80 Product Line By Rod Blocksome, KODAS



**From the Editor's Desk**

by Bill Carns, N7OTQ and Co-Editor Joe Nyberg, WILJN

Wild and crazy quarter! Along the way, due to unforeseen circumstances internationally, we had to change the entire plan for this issue of the *Signal Magazine*. As I am sure most of you know, because of the international flavor of the Collins Collectors Association, I like to make the first issue of each year have a very definite international flavor. That will not happen this year until maybe later in the year.

In the meantime, it has been a good quarter. I will cover a lot of this in the President's column, but here I will say that the organization is rebounding from the impact of the economy and the activity is going up. I do hope that those of you that tackled winter restoration projects (and I have heard of a few that I am tracking) will consider writing them up and submitting them to this editor, so that we can all share your trials and successes.

This month we are privileged to have two of our past very prominent writers back to contribute to our knowledge base and I, for one, enjoy reading the works of both of them. Rod Blocksom - recently retired from a long and successful career with Collins Radio - has done a very good article on the hugely successful Rockwell Collins product line known as the HF-80 family. I know that you will enjoy that. And, Dick Weber, having written for the *CCA Signal* many times before, has submitted several articles and the first of these will be appearing in this issue. Thanks to both of you and

without this kind of contribution, I would be lost for sure.

The *Signal* is typically a bit late in Q1, and this one is no exception, due to the need to get the details of the Dayton Hamvention in. This time, I am happy to say, there is another reason too. The President will make the official announcement, but I am sure he won't mind if I give you a sneak peak - sort of. After many requests, the CCA has added a Dallas Ham-Com event to this year's schedule. It will be similar in content and happenings to the Dayton Hamvention. We wanted to get this all arranged and get the details in this issue so that you all could make plans early. I hope that, between the two events now, we will be seeing many more faces in person.

Personally, I am still connecting equipment and enjoying that aspect of my life. I have let too many projects get going at once and that makes me a bit edgy, but I am working them down. When a new radio jumps out at you, it just jumps out at you.

Enjoy the issue. Enjoy your hobby. Keep letting me know what you are looking for - and we will keep on trying to get it right here at CCA Central.

Best 73s, Bill, N7OTQ

512 847-7019 Home

512 618-2762 Cell + VM

wcarns@austin.rr.com

**READ ME = = = = = >**

**Dayton Upon Us  
AND . . Here Comes  
Dallas**

Thinking about going to the Dayton Hamvention this year? Well, now is the time to make your reservations if that is in the offing. Hotel rooms are filling up and the banquet is booking as we speak.

This will be a great year, I know. We have the good fortune of having Jim Maccani, WOHUP - and the Collins factory Customer Service Manager for the KWM-380 - as our speaker this year at the banquet.

Jim is going to talk about his "Baby" and the changes and modifications that occurred during its production. This is not to be missed. Please see the CCA website for detailed information and reservations.

All in all, this looks like another banner year for the CCA at Dayton.....Ya All Come.

**AND.....In response to the many that have been asking for similar events at other major swap meets.....Here Comes Dallas.**

This year, on the weekend of June 10, the CCA will be holding a event similar to Dayton at the 2011 Dallas Ham-Com.

Please see the notice on the CCA website and make your banquet reservations early so you do not miss out. We are reserving the back room at a local restaurant close to the arena, and space is limited.

The CCA will also have a booth inside the Ham-Com site with some very interesting goodies.

## 30L-1 Meter Calibration for Reading Plate Current

by Dick Weber, K5IU



You would think that something as simple as having the meter of a 30L-1 accurately read plate current wouldn't be a big deal. Well as they say, "The devil is in the details." I found this out when I replaced a damaged meter in one of my 30L-1s after there was a problem that resulted in excessive plate current being drawn. After repairing damage to the power supply board and installing a new meter, the indicated current was way too high with only a few milliamperes pegging the meter. It took only a minute to find out what was causing this and, even then, the first attempt to fix the calibration was only partially successful. I eventually got it fixed - an error in my 30L-1 manual didn't help. But it did cause me to devise a method to check the meter calibration where the amplifier doesn't have to be powered-up and does not require any temporary modifications such as disconnecting a component or lifting a lead.

I need to point out that this 30L-1 doesn't use the original power supply boards, but uses

one of the currently available replacement power supplies. One difference is that the replacement supply uses two 2 Ohm, 5%, 3 Watt resistors in parallel to make R8 while the original power supply uses a 1 Ohm, 1%, 5 Watt resistor.

When excessive current was drawn from the power supply in this 30L-1 the meter shunt resistor, R8, opened up while the two 10 Ohm paralleled resistors, R17 and R18, didn't fuse. When R8 opened (both 2 Ohm resistors), current flowed through R10, which is hooked to ground through the meter when the meter selector switch is in the D.C. AMPS position. This can be seen in the simplified schematic in **Figure 1** with R8 and R10 highlighted. The result was a damaged meter in addition to R8. After the power supply board was repaired and a new meter was put in, I was surprised to see the meter would peg when only plate idling current was being supplied.

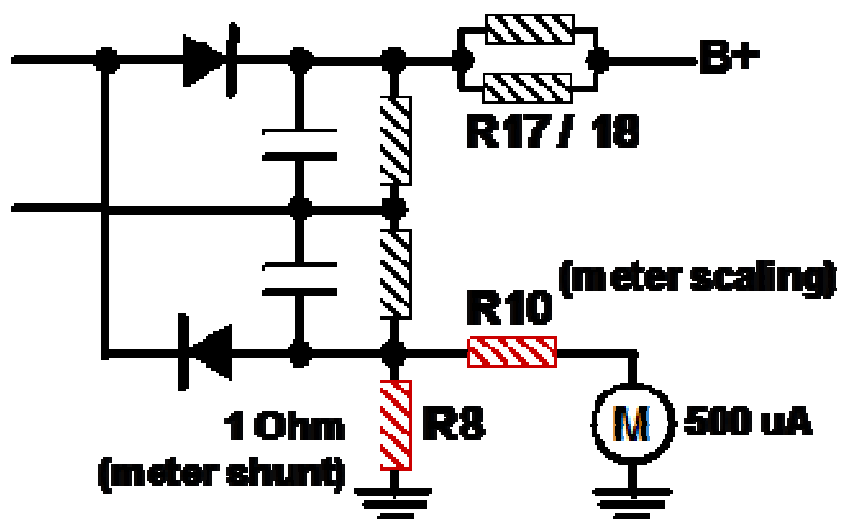

**Figure #1 – Simplified Schematic Showing R8 and R10**

A check of R10 showed it to be about 83 Ohms, which did not agree with the value of 1960 Ohms shown in my 30L-1 manual. Also, this value was obviously incorrect based on the function it performs in the meter circuit. Apparently when R8 went open the resulting high current in R10 dramatically altered its resistance. At this point, I replaced R10 with a 2000 Ohm resistor. Now the meter did not peg, but when the amplifier was fully loaded the indicated current seemed a bit low.

## 30L-1 Meter Calibration for Reading Plate Current (Cont'd)

by Dick Weber, K5IU

To be able to test the meter circuit a method was devised that doesn't require the 30L-1 to be powered-up or use any temporary circuit modifications. To do this, a low voltage DC power supply was used to cause 1 amp to flow through the R8/R10 combination. This was done by having the DC power supply hooked to a series circuit consisting of a digital meter used to measure current, a wire wound resistor combination of about 6 Ohms from my junk box, and R8. Clip leads were used to connect to both ends of R8. By using clip leads no soldering or part removal was needed. **Figures 2 and 3** show how this approach was implemented. (The role of the 6 Ohm resistor was to ensure that the power supply had to be set at a voltage more like 7 Volts to allow adequate control of the current by not operating near the low end of the supply's voltage range with a 1 Ohm load.)

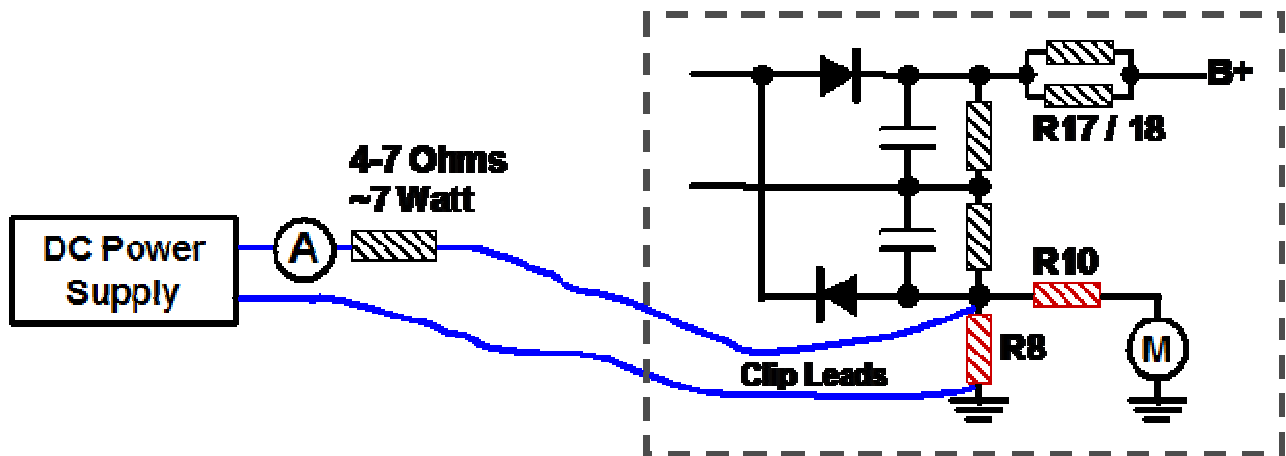

Figure #2 - Meter Calibration Test Circuit - Above

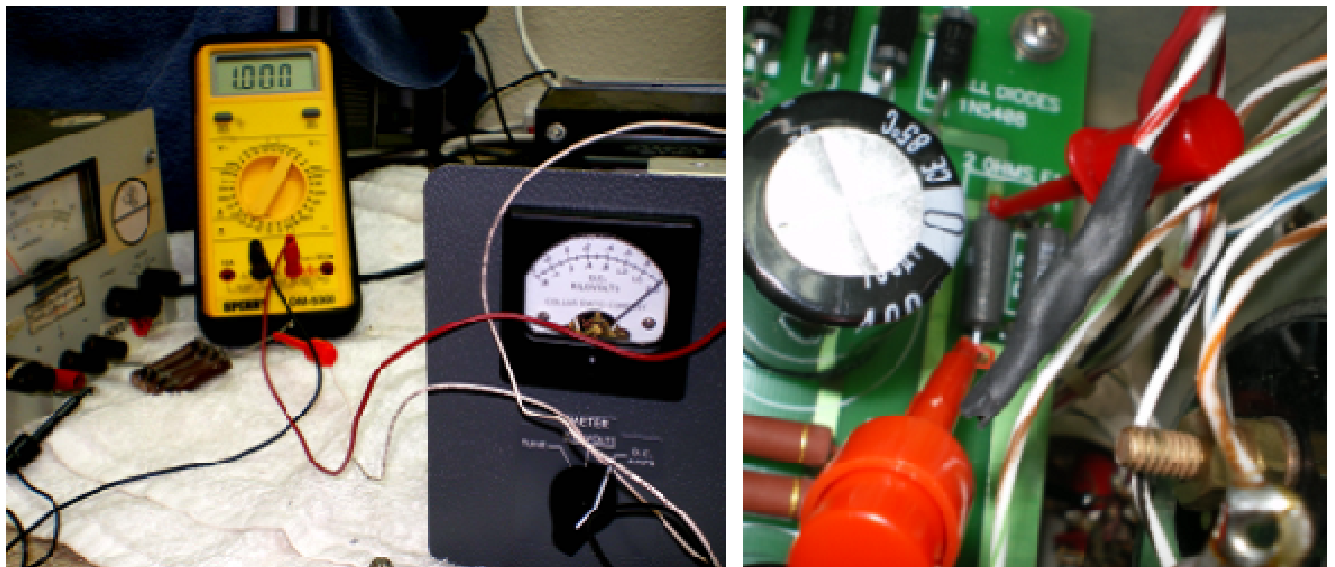

Figure #3 - DC Power Supply and Test Circuit Connected to R8

## 30L-1 Meter Calibration for Reading Plate Current (Cont'd)

by Dick Weber, K5IU

With a 2000 Ohm resistor used for R10 and the test circuit set to flow 1 ampere, the 30L-1 meter indicated about .85 amps. Although the schematic called for R10 to be 1960 Ohms, clearly this value was not right. It became apparent 1960 Ohms didn't account for the meter's resistance. Just so happens the printed value for R10 on the damaged resistor was so faded it couldn't be read. At this point, I was not sure what was the correct value was for R10 and also realized there could be a small error introduced by R8 being a 5% resistor rather than a 1% resistor.

In all of this it appeared as though there was an opportunity to determine a value for R10 that accounted for the meter's resistance and for R8 not being exactly 1 Ohm. To find the optimal value for R10, the 2000 Ohm resistor installed for R10 was removed and a 3K Ohm pot with foot long leads was wired in its place. By varying the 3K pot, a setting was found that resulted in agreement between the 30L-1 meter and the test circuit meter. This was done using 1 amp, which is full scale on the 30L-1 meter. Measuring the pot setting gave a value of 1732 Ohms. As a result, a 1740 Ohm, 1/4 Watt, 0.1% resistor was installed for R10.

After the new R10 was installed, I investigated the difference between the 1960 Ohm value for R10 called out in my manual and my 1740 Ohm. My manual (Fourth edition - June 1, 1961) and the fifth edition (June 15, 1962) downloaded from the CCA website, show R10 to be 1960 Ohms. With the help of Jim, N4AL and Dick, KC9GSM, I found that, starting with the sixth edition (June 15, 1964), the value for R10 is listed as 1780 Ohms. Mystery solved - early manuals show the wrong value for R10.

Going forward here's what can be taken away from this:

- If you are using the original power supply and have to replace R10, you should use a 1780 Ohm, 1/4 Watt, 1% resistor. If you're using a replacement power supply you could use the same value for R10 and be assured of reasonably good meter accuracy for reading late current.
- The next time you have your 30L-1 out of its cabinet, you might want to check to see R10 is the correct value just in case someone replaced it with a 1960-2000 Ohm resistor.
- If you have to replace R8, you might want to check the overall meter calibration using the test set-up shown in **Figures 2 and 3**. This will assure you your meter is reasonably accurate.
- If you're doing upgrades to you 30L-1, you may want to check the meter calibration as part of your overall efforts.

Or if you're really curious about the accuracy of your plate current readings, you can check it using the test set-up shown in **Figures 2 and 3**. If you're not happy with the accuracy, you can use the method discussed above to find the optimal value of R10, which in my case was 1740 Ohms. If you do this, be sure to use a 1/4 Watt, 0.1% resistor for R10. The 1740 Ohm, 0.1% tolerance, 1/4 Watt resistor I used came from Mouser - their part number 66-RC55LF-D-1.74K. Their part number for a 1780 Ohm version is 66-RC55LF-D-1.78K.

In hindsight if I had originally known R10 was supposed to be a 1780 Ohm resistor, I probably would have installed one and been happy. But if I hadn't had this adventure, a simple way to check meter calibration and, if needed, a way to find an optimal value for the meter scaling resistor wouldn't have come

**The Rockwell Collins HF-80 Product Line (Cont'd)**

By Rod Blocksome, KODAS

The Rockwell Collins HF-80 equipment is increasingly available on the surplus market and has caught the attention of Collins Collectors. Back in the late 70's and early 80's I designed some of the HF-80 equipments and now take this opportunity to share some information that may be beneficial to the collector, restorer, and user of HF-80. The cover photograph is an example of what a basic HF-80 1kW station looks like.

The term "HF-80" denotes a family of HF equipment with standardized interfaces providing the flexibility to create a large variety of HF systems. The standardized interfaces were defined very early in the design phase along with a number of other aspects including the styling, human factors, and maintenance features to name only a few. Equipment type numbers were assigned according to a master plan evident in Table 1 - a listing of the major equipments. The HF-80 family also included a large number of accessories with "AC-80XX and AC-81XX" type numbers, cabinets with "CA-80XX" type numbers, test sets with "TS-80XX" type numbers, and microphones with "SM-XX & MM-XX" type numbers. Additionally, HF Systems of HF-80 equipments, carry type numbers of "HF-81XX". There are instruction manuals published for these system type numbers as well as the individual equipments.

Within a specific model, there evolved many variations denoted by different top level part numbers - usually distinguished by the "dash number" which is the last three digits of the Collins 10-digit part

**Table 1 - HF-80 Major Equipment List**

**Table 1-A**

<b>Model No.</b>	<b>Equipment</b>	<b>Distinguishing Features</b>
IIF-8010	Exciter	2 Channel ISB; 1.6-30 MHz; Local Control Only
HF-8010A	Exciter	2 Channel ISB; 1.6-30 MHz; Local or Remote Control
HF-8014	Exciter	4 Channel ISB; 1.6-30 MHz; Local Control Only
HF-8014A	Exciter	4 Channel ISB; 1.6-30 MHz; Local or Remote Control
HF-8020	Power Amplifier	1kW; 1.6-30 MHz; Tube Type; Use HF-8030 PS
HF-8021	Power Amplifier	3kW; 2.0-30 MHz; Tube Type; Internal 3-phase PS
HF-8022	Power Amplifier	10kW; 2.0-30 MHz; Tube Type; Internal 3-phase PS
HF-8023	Power Amplifier	1kW; 1.6-30 MHz; Solid State Type; Use HF-8031/8032 PS
HF-8030	Power Supply	Single Phase; Use with HF-8020 PA
HF-8031	Power Supply	Single Phase; Use with HF-8023 PA
HF-8032	Power Supply	Three Phase; Use with HF-8023 PA
HF-8040	Antenna Coupler	Analog Tuning; 1.6-30 MHz; Use with HF-8020 or HF-8023
HF-8041	Antenna Coupler	Digital Tuning; 1.6-30 MHz; Use with HF-8023
HF-8050	Receiver	2 Channel ISB; 0.25-30 MHz; Local Control Only
HF-8050A	Receiver	2 Channel ISB; 0.25-30 MHz; Local or Remote Control
HF-8054	Receiver	4 Channel ISB; 0.25-30 MHz; Local Control Only

**The Rockwell Collins HF-80 Product Line (Cont'd)**

By Rod Blocksome, KODAS

number. When repairing and restoring the HF-80 equipment, it is very important to pay close attention to the top level part number of the cards, modules, and subassemblies. Closely associated with the part number is the Manufacturing Control Number or MCN and the Revision or REV letter. The MCN is like a serial number that is used in the factory to track the item through the production processes. The REV letter indicates changes that have occurred since the design was originally released to the factory. Many revisions have nothing to do with the performance of the item, so don't be too concerned if you see wide ranges of REV letters on subassemblies in the same piece of equipment. Revisions that do affect performance will trigger the issuance of a Service Bulletin (SB) or in some instances a Service Information Letter (SIL) if it is of a minor nature.

Table 1-B

HF-8054A	Receiver	4 Channel ISB; 0.25-30 MHz; Local or Remote Control
851S-1(A)	Receiver	2 Channel ISB; 0.25-30 MHz; Tuning Knob Control
HF-8060	Pre/post-selector	Analog Tuning; 2.0-32 MHz; Use with exciters, receivers, and transceivers
HF-8061	Line Flattener Filter	2-pole high power, bandpass filter plus line flattener (match up to 3:1 SWR); 1.6-30 MHz; Use with HF-8020 or HF-8023 PA
HF-8062	Low Pass Filter	1.6-30 MHz; Additional harmonic filtering; Use with HF-8020 or HF-8023 PA
HF-8064(B)	Pre/post-selector	Digital Tuning; 2.0-30 MHz; Use with exciters, receivers, and transceivers
HF-8070	Receiver/Exciter	2 Channel ISB; 0.25-30 MHz Receive, 1.6-30 MHz Transmit; Local Control Only
HF-8070A	Receiver/Exciter	2 Channel ISB; 0.25-30 MHz Receive, 1.6-30 MHz Transmit; Local or Remote Control
HF-8090	Remote Control	Remote control of HF-8010A exciters via serial data
HF-8091	Remote Control	Remote control of HF-8050A receivers via serial data
HF-8092	Remote Control	Remote control of HF-8070A transceivers via serial data
HF-8093	Remote Control	Remote control of HF-8014A exciters via serial data
HF-8094	Remote Control	Remote control of HF-8054A receivers via serial data
HF-8095	Remote Control	Remote control of 851S-1A receivers via serial data

Commercial, military, and international customers of HF systems have requirements that may seem strange to the average amateur operator. When compared to similar amateur equipment, HF-80 seems very expensive, physically large, and somewhat lacking in “bells and whistles”. This is driven by rigid adherence to specifications that are tested and verified for compliance, high reliability and environmental conditions (temperature range, altitude, shock, vibration, and EMI) well above typical amateur applications. For example, let's consider a transmitter's rated power output. An HF-80 1kW power amplifier will deliver 1,000 Watts continuously, at any frequency between 1.6 to 30 MHz, operating at 10,000 feet altitude (thin air for cooling) and at +50 degrees C. ambient air temperature. By compari-

**The Rockwell Collins HF-80 Product Line (Cont'd)**

By Rod Blocksome, KODAS

son, an amateur amplifier will typically have “slightly lower output on 10 meters” and a maximum key down time of (perhaps) 5 minutes or less if it’s even specified and at room ambient temperature. The lack of “bells and whistles” is briefly explained by the differences between an amateur operator who operates anywhere within the amateur bands and is subjected to a much wider range of adverse conditions such as noise and interference. The commercial or military operator requires a higher degree of automation of radio functions and always operates on pre-assigned frequency channels. An amateur operator will thus find cumbersome the thumbwheel frequency selection switches on the HF-80 radios instead of the velvet smooth, weighted main tuning knob found on today’s amateur transceivers. What are some of the advantages and disadvantages of using HF-80 equipment on the ham bands? Here are a few things to consider as you contemplate such a project.

**Transmitter Linearity and Harmonics** - The linearity of the HF-80 transmitters and output on harmonic frequencies is generally much better than commercial amateur gear. Note - when comparing two-tone IMD specifications amateur equipment is customarily referenced to peak envelope power (PEP) whereas HF-80 and most commercial/military HF transmitters are referenced to the power level of the two tones. There is 6 dB difference between PEP and the two tone level. Table 2 compares some of the high end amateur linear amplifier specified two-tone IMD and harmonics with the HF-80 PA’s. All IMD figures are referenced to PEP for easy comparison.

**Table 2 - PA IMD and Harmonic Specifications**

Amplifier	Tube/S.S.	Rated Output	IMD rel. PEP	Harmonics
ICOM IC-PW1	S.S.	1.0 kW	No Spec	<-60 dB Spurious
Yaesu VL-1000	S.S.	1.0 kW	<-30 dB Typical	<-50 dB Spurious
<b>RCI HF-8023</b>	<b>S.S.</b>	<b>1.0 kW</b>	<b>&lt;-36 dB</b>	<b>&lt;-55 dB</b>
ACOM 2000A	Tube	1.5 kW	<-40 dB (3 <sup>rd</sup> ) <-45 dB (5 <sup>th</sup> ) Typical	-55 dBc (2 <sup>nd</sup> ) -70 dBc (3 <sup>rd</sup> & higher)
Alpha 9500	Tube	1.5 kW	<-30 dB	No Spec -45 dBc Measured
Ameritron AL-1200	Tube	1.5 kW	-34 dB (3 <sup>rd</sup> )	No Spec
<b>RCI HF-8020</b>	<b>Tube</b>	<b>1.0 kW</b>	<b>-41 dB</b>	<b>-55 dBc</b>
<b>RCI HF-8021</b>	<b>Tube</b>	<b>3.0 kW</b>	<b>-46 dB</b>	<b>-80 dBc</b>
<b>RCI HF-8022</b>	<b>Tube</b>	<b>10 kW</b>	<b>-46 dB</b>	<b>-80 dBc</b>



## HF-80 Product Line (Cont'd)

**Output Power into Load SWR** - Another important difference between Collins HF-80 transmitters and typical amateur amplifiers is delivered power into mis-matched load impedances (loads presenting an SWR). Keep in mind that the antenna can only radiate the amount of power delivered into its feed-point impedance less antenna ohmic losses. The delivered power (sometimes called true power) is the forward power minus reflected power. The HF-80 tube-type PA's deliver their rated power into load SWRs of 3:1 or less. For example, when the HF-8020 PA automatically tunes into an antenna load of 3:1, the measured forward power will indicate 1,330 Watts and the reflected power will indicate 330 Watts for a delivered power of 1,000 Watts. The solid state HF-8023 PA has a broadband output and thus its output power decreases with increasing load SWR above 1.3:1. Its forward power output is not less than the curve defined as 1,000 Watts divided by the SWR.

**Receiver Sensitivity and Strong Signal Specifications** - The HF-80 receivers may have either a "standard" or "high performance" RF Translator module. The two have the same specifications unless stated otherwise. Receiver RF input for a 10 dB (S+N)/N is:

Standard Translator:

250 to 1600 kHz: SSB 2.0  $\mu$ V, AM (30% modulation) 16.5  $\mu$ V

1.6 to 30 MHz: SSB 0.7  $\mu$ V, AM (30% modulation) 5.7  $\mu$ V

High Performance Translator:

250 to 1600 kHz: SSB 5.6  $\mu$ V, AM (30% modulation) 23.1  $\mu$ V

1.6 to 30 MHz: SSB 1.1  $\mu$ V, AM (30% modulation) 11.4  $\mu$ V

This may seem counter-intuitive but the high performance translator is slightly less sensitive than the standard translator. The reason is found in the strong signal intermodulation distortion (IMD) specifications:

In band IMD with two input signals each at 0.1 Volt is -47 dB below either tone for both the standard and high performance translators.

Out of band IMD with two input signals each at - 15 dBm and 50 kHz or more off the receiver tuned frequency:

Standard Translator is - 60 dB for 2<sup>nd</sup> order products & - 60 dB for 3<sup>rd</sup> order products

High Performance Translator is - 65 dB for 2<sup>nd</sup> order products & - 100 dB for 3<sup>rd</sup> order products

The bottom line is both translators perform quite well on the ham bands. The high performance translator is more complicated and more difficult to trouble-shoot and repair. Enhanced front-end selectivity can easily be obtained by adding one of the HF-80 pre/post-selectors to the receiver.

**Automatic Tuning** - In all of the HF-80 systems, tuning to a new frequency is automatic. This is perhaps one of the more fascinating features for the amateur operator. For example, change the frequency on a receiver (or exciter) by 10 Hz or 28,894.32 kHz and the receiver (or exciter) retunes in 2 milli-seconds! Add an HF-80 pre-selector and the answer is the same only the tuning time depends upon the exact model of pre-selector. The standardized interfaces and interconnect cables make automatic tuning possible with the whole range of possible HF system configurations.

The transmitters automatically tune and match to the antenna load. The large HF-8022 10kW PA will automatically tune-up in typically 6 to 10 seconds depending upon frequency excursion and load SWR while the solid state 1kW PA tunes in 350 milli-seconds maximum. Add the HF-8040 antenna coupler and a random length wire antenna to the HF-8023 PA and the answer is the same except the system tuning time is on the order of 6 to 10 seconds typically due to the analog servo tuning of the coupler elements. The antenna coupler automatically tunes and matches the antenna impedance to 50-ohms with an SWR of 1.3:1 or less thereby allowing the solid state PA to deliver a full 1kW output power.

Automatic tuning brings with it many circuits requiring critical adjustment and alignment not found in amateur gear. Unless you are intimately familiar with the HF-80 equipment, it is highly recommended that you carefully read and comprehend the instruction book before restoring or repairing this equipment.

## HF-80 Product Line (Cont'd)

**Frequency Controls** - The HF-80 frequency controls are one of the less desirable features for amateur operation. Thumbwheel decade switches control the frequency synthesizer to select the operating frequency. "Cruising" the ham bands with these switches is inconvenient to say the least. However, for certain operations such as SSTV, BPSK, Nets, the 60 meter band, and MARS some may find it acceptable or even desirable. The HF-80 frequency synthesizer is a decade design which provides for tuning resolutions of 100 Hz, 10 Hz, and even 1 Hz by simply adding decade cards. A common frequency synthesizer is used in the exciters, receivers, and transceivers. Most HF-80 exciters were only implemented with 100 Hz tune steps - adequate for almost all channel frequency assignments. The HF-80 receivers were a mixture of 100 Hz and 10 Hz steps. Receivers with 1 Hz tune step were rare since that capability was export restricted in the 1980's.

**Unique Features** - HF-80 has some unique features not typically found in amateur gear and therefore not familiar to hams. Independent Sideband (ISB) mode is the simultaneous transmission (or reception) of more than one sideband - each containing different information. For example, the lower sideband could contain voice modulation while the upper sideband could contain data. Typically ISB is used in full duplex HF circuits. One possible use of ISB for amateurs would be to transmit a SSTV picture on one sideband with voice narration on the other sideband simultaneously. The ISB capability is the reason you find both USB and LSB filters as well as dual audio channels in the two channel ISB HF-80 equipment.

The dual audio channels, labeled "Ch A and Ch B" may cause some initial confusion. All emission modes use Channel A audio. The only time Channel B audio is active is when it is needed for two channel ISB mode. In that case, USB audio is on channel A and LSB audio is on channel B. Similarly, the four channel ISB radios have UUSB=Ch A2; USB=Ch A1, LSB=Ch B1, & LLSB=Ch B2. There are a couple of things to be aware of regarding the HF-8054(A) and HF-8014(A) 4ISB radios. The "outboard" channels are inverted. In other words, audio channel A2 is UUSB but it is really a lower sideband signal. Likewise channel B2 is LLSB but it is really an upper sideband signal. I can think of no useful application of the UUSB or LLSB chan-

nels in amateur radio. However, to meet military specifications for four channel HF equipment, the IF filters must have very steep skirts to minimize mutual co-channel interference. You will find very large, high performance, crystal filters in the HF-8014 and HF-8054 four channel radios and standard Collins mechanical filters in the HF-8010 and HF-8050 two channel radios.

The HF-80 exciters include an "AM Mode" which is actually Amplitude Modulation Equivalent (AME). AME is the carrier and only the upper sideband thus occupying only 3 kHz of bandwidth rather than 6 kHz for normal AM on HF. It is detected by the receiver in the same manner as normal AM. However, there is an inherent 14 % total harmonic distortion (THD) with AME compared to AM but it's hardly noticeable in voice communications applications. Amateurs wishing to use AM can do so with the HF-80 transmitters and occupy only half the normal bandwidth of a full double-sideband AM station. The receivers and exciters have 600-ohm balanced line audio inputs and outputs to facilitate connections to telephone line circuits or external data modems. The receivers also have 450 kHz IF outputs on the rear to allow connection of ancillary equipment. The receivers have an internal local speaker with a squelch function, headphone jack, and provisions for connecting an external speaker. The front panel headphone jack on the exciters allows monitoring the incoming line audio from the front panel.

A front panel analog meter provides monitoring of audio levels on inputs/outputs. Additionally, the exciter RF drive level is measured on the meter. The receivers have a received signal level meter position. However, the meter scale is not calibrated in S-units as found on ham transceivers. Instead it reads in dB relative to a 1-microvolt signal. Thus "S-9" would be "40 dB" on the HF-80 receiver - if you accept that a 100-microvolt signal is the "standard" for S-9.

**Extra IF Filter Bandwidths** - The HF-80 receivers come equipped with either two or four sideband filters plus the receivers have a 16 kHz LC filter for AM reception. The receivers have provision for additional IF filters that are mounted on a "piggy back" board which plugs onto the Channel A IF Card. There is room for five additional mechanical filters. The receiver front

## HF-80 Product Line (Cont'd)

panel bandwidth switch has the following positions: 16 kHz (LC band pass), "A" optional filter, "B" optional filter, "USB" typically 2.85 kHz filter, "LSB" typically 2.85 kHz filter, "C" optional filter, "D" optional filter, and "E" optional filter. Various filters can be installed in the optional positions. Typical bandwidths commonly used are 0.2, 0.3, 0.5, 0.7, 1.0, 3.0, and 6.0 kHz. The last IF frequency is 450 kHz for all HF-80 equipment.

**Useless features for Hams** - There are a couple of features in the HF-80 systems for which I can foresee no use at all for amateurs. However, amateur innovation will undoubtedly disprove this assumption. The HF-80 exciters have a "Pilot Carrier" switch. When enabled, the normally suppressed carrier of a SSB or ISB signal is inserted at a nominal level of 26 dB below rated transmitter PEP output. This allows HF-80 receivers incorporating the Automatic Frequency Control (AFC) option to lock onto the transmitter's precise frequency. Pilot carrier and AFC are used with certain types of data modems and when the frequency stability of the transmitter is not adequate or, as is more frequently the case, one of the HF stations is on a moving aircraft whose Doppler shift must be compensated. If you accidentally turn the pilot carrier switch on, someone will give you a report of "a poorly suppressed SSB carrier".

**HF-80 Remote Control** - There are three types of HF-80 systems: Receivers, Transmitters, and Transceivers and each may be remotely controlled and monitored using serial data. The remote control/monitor may be either a computer or the appropriate HF-809X equipment. The instruction books provide detailed information on the command structure to enable one to write custom computer control software. Depending upon which remote control card set is implemented in a particular HF-80 exciter, receiver, or transceiver, the following types of serial control may be used:

- RS-232, ASCII or 8-bit word format, 75 to 19,200 bps, one remote (HF-809X) can control up to 16 radios - each with a unique address
- FSK, HF-80 8-bit word format, 75 to 600 bps, one-to-one control

Remote control of a receiver is straightforward and easy to visualize. In the case of a transmitter or transceiver, the remote control "talks" directly to the HF-80 exciter or transceiver which in turn

control and monitor their associated power amplifier, power supply, and any additional transmit system equipment.

All HF-80 power amplifiers use the standardized control interface which is hardware control. RF drive level for all PA's to make rated output power is NMT 100 mW (+20 dBm). The maximum recommended distance between the exciter and the PA is 150 feet. The exciter connected to a PA becomes a transmitter. Local control of this transmitter is exclusively from the front panel of the exciter. Remote control/monitoring of this transmitter may be accomplished by serial data to/from the exciter.

An amateur remote base HF station would seem to be an application well suited for HF-80 but to date I don't know of an amateur that has done it. If you own some HF-80 equipment or intend to get some, there are resources out there for equipment, parts, information, and guidance. Good Luck and happy hunting.

### HINTS AND KINKS FOR USING HF-80 SURPLUS By Rod Blocksom, KODAS

1. The small "drop-style packaged" Tantalum capacitors are the bane of problems encountered in the receivers and exciters. Over the years some of them become leaky or short. Some methods of detection include:

- Look for obviously overheated capacitors (discolored)
- Look (with a small magnifying glass) for a tiny split or a tiny sphere of "solder" on the capacitor surface
- Feel for capacitors that are noticeably warmer than room temperature after equipment has been powered up for some time.
- Old fashioned trouble-shooting with a good VOM

2. The heat sink grease on the high power transistors in the HF-8023, 8031, and 8032 deteriorates after a few decades. I recommend NEVER turning on an HF-8031 or HF-8032 power supply without first cleaning off the old grease and replacing with new under the TO-3 power switching transistors in the 1,000 W and 500 W power converter modules. These transistors are special, expensive, beta matched, and no longer manufactured by Motorola. The same advice applies for the RF power transistors in the HF-8023 PA.

## HF-80 Product Line (Cont'd)

However, frequently just re-torque of the mounting screws has been found adequate.

3. The three-phase HF-8032 Power Supply seems to be more plentiful on the surplus market than the single phase HF-8031. However, the HF-8032 can be run on single phase provided one connects the line to J1-1 and J1-10. The single phase transformer for the low voltages will be connected and the high power off-line switching converters will work fine with either single or three phase AC power.

4. There are three levels of frequency stability/accuracy available for the HF-80 receivers and exciters depending upon top level status and/or options installed. The lowest, most basic frequency reference for the synthesizer is the built-in temperature compensated crystal oscillator (TCXO) located on the "REF STD" synthesizer card. The HF-80 oven standard module provides the next level up. An external reference standard, such as a Rubidium standard, can be connected to the HF-80 receivers and exciters for the ultimate in frequency accuracy and stability. The optional internal automatic reference standard switch module will connect the synthesizer to the internal oven standard if the external one fails or is disconnected. If the internal or external oven standards are added to an exciter or receiver, be sure to follow the instruction book in setting the appropriate jumper straps in the synthesizer.

5. There are Transmit/Receive (T/R) Relay modules for all HF-80 PA's. However, not all PA's will have them since split-site HF ground stations do not require them. The receivers have a "mute" function but the exciters do not have an output line to drive the receiver mute. A simple modification can be made to the exciters by adding a wire to bring the "System Key" located on J15-2 to TB2-8 located on the exciter's rear panel. Connecting TB2-8 to the associated receiver's mute allows for "transceive" operation using a separate receiver and exciter.

6. Interconnect cables are typically missing on the surplus market. Fabricating the cables is not an easy task but with dedication and hard work can be accomplished. The connectors are currently still available from industrial electronics suppliers. The proper crimping tools are re-

quired to fabricate the cables for the HF-8023/8031/8032 equipments. The cable diagrams with connector types are in the HF-80 instruction books.

7. The HF-80 Power Amplifiers have a fairly high level of blower noise. It is highly recommended that they be located well away from the operating position - even in a nearby room. The receiver and exciter or HF-8070 transceiver could be placed in the operating position with connecting cables up to 150 feet to the PA/PS.

8. When using a separate receiver and exciter, both should operate from the same frequency standard. This will ensure that both are on exactly the same frequency when their dials are set the same. A surplus Rubidium standard is an excellent solution. Alternatively, it is possible to use the HF-80 internal oven standard in one unit to drive the other unit. As a last resort, the HF-80 internal TCXO's inside the Synthesizers can be used but set them up using a good quality frequency counter. This is not an issue when using the HF-8070 transceiver since a common synthesizer is used for transmit and receive.

9. The HF-8040 1kW antenna coupler allows the HF-80 transmitter to use almost any length of wire or whip as the antenna. It should be at least 35 feet long for good operation on 160 meters. It is very important that the coupler case be well grounded at the antenna feed-point. The coupler control cable must be shielded and installed away from the antenna as much as possible.

10. The HF-8061 High Power Filter & Line Flattener is a unique but somewhat scarce piece of equipment. It contains an automatically tuned 2-pole bandpass filter in addition to an impedance matching network. The unit is designed to go on the output of either the HF-8020 or HF-8023 1kW PA. It is used in systems located in close proximity to other high power HF transmitters. The Line Flattener impedance matching network will match any antenna feed-point impedance of 3:1 SWR or less to 1.3:1 or less over the 1.6 to 30 MHz range. It is an ideal addition to an HF-80 system using the HF-8023 Solid State PA.

11. The HF-8062 Low Pass Filter unit contains eight fixed tuned, high power, low pass filters covering 1.6 to 30 MHz. The filter is used with the 1kW HF-80 PA's to provide additional attenuation of the transmitter harmonic frequencies. de Rod, KODAS .....CCA.....

## HF-80 Product Line - Author Information and Editor's Comments



Rod Blocksome, KODAS, has written for the *Signal Magazine* several times before. More importantly, Rod is a staunch supporter of the CCA and is responsible for much of the background information on the S-Line and other Collins equipment on our website. He is now retired after more than 40 years with Collins and Rockwell Collins.

He lives with his wife in Cedar Rapids, and is now an active Collins collector after encountering our founder, Bill Wheeler, when he visited the Collins plant..

Rod has been a ham since 1960 when he became KN0DAS. He is very active, not only operating his Collins gear, but supporting the ARRL and our group.

He has both a BS and MS degree in Electrical Engineering and was the Project Lead on many of the HF-80 high power amplifiers and systems that he writes about in this issue. He also enjoys photography, traveling, a bit of astronomy and searching for Emilia Earhart's final resting place. Thanks Rod!

.....CCA.....

**Editor's Note:** Maintainability of the various HF-80 systems is very good. The following figures will give you a pretty good idea of the modular construction involved. Notice that, in the opened up receiver shown below, almost all cards have their critical voltages and test signals brought out to the top edge of the card - while inserted. This makes trouble shooting at the first level very easy. The other two photos below show the modular nature of both the 8023 and the related power supply. Note the generous use of removable modules in both.

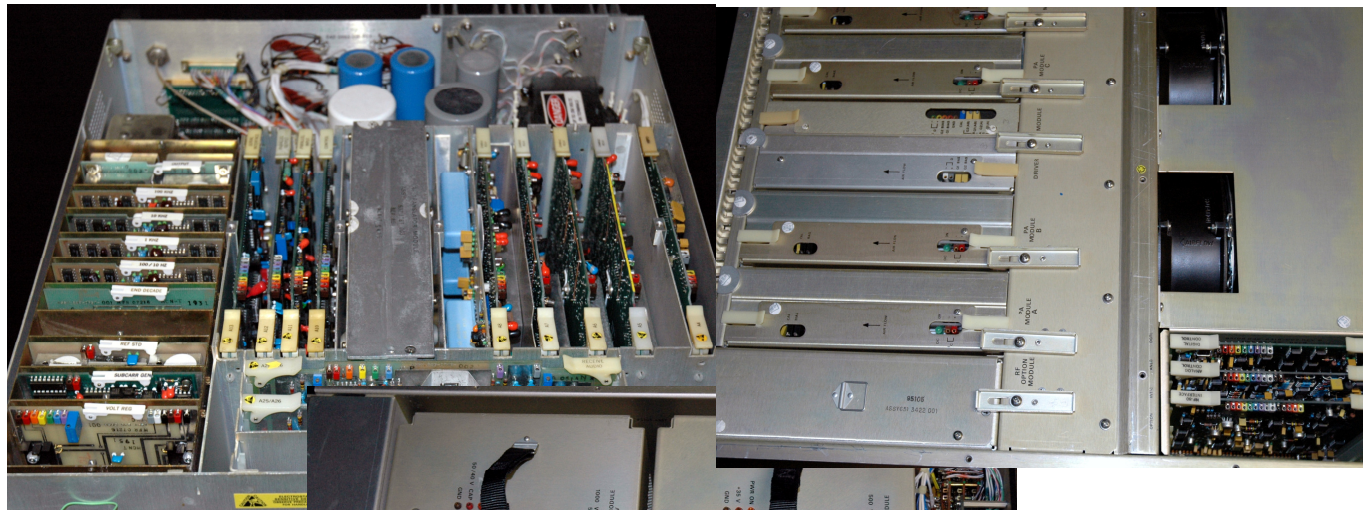

HF-8054A Rcvr w/ cover open above.

Note the copious use of test jacks on the edge of the PC cards.

Right: Modular P.S. construction.

HF-8023 SS 1 kW PA above - showing the cover off and the modular nature of this amplifier. Note also the use here of the diagnostic test points in the lower right.

## Service Line - 30L-1 Meter Cal - (Cont'd)

to light. So I guess I'm glad I had this journey. You should be able to adapt this method to check the meter circuits in other types of equipment.

### Author Information Dick Weber (K5IU)



Dick has previously written for the *Signal Magazine* and we are glad to have him back. Although employed as a Principal Engineering Fellow (Specializing in M.E.) by Raytheon, Dick has been a ham since 1974 and is published often in CQ and QEX with a strong bent towards Antenna design. He also has had his own company specializing in Rotating towers.

Dick's primary interests in Collins center around the S-Line and he is most often heard on CW. Welcome back Dick.....cca....

## CCA ELECTION RESULTS An Update

As you know, during Q4 2010, nominations were opened for the two outgoing CCA Board of Directors positions held by Jim Green, WB3DJU, our then Treasurer, and Butch Schartau, W0BS. Only two names were placed in nomination, one for each position, so the election was declared a "No Contest" election and ballots were not mailed.

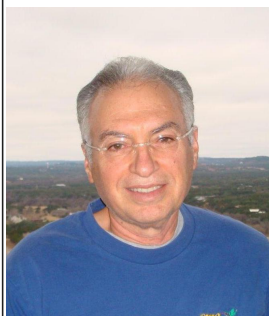

**Ron Freeman, K5MM** was elected to Jim Green's position and then elected Treasurer by the Board of Directors. He is a retired CPA and formerly served as CCA treasurer in the late 1990s. In the first 20 years of his career, he specialized in corporate taxation and partnership syndication matters. For the last 15 years, he provided expert testimony in Federal and state courts regarding damage and valuation matters. Ron was first licensed as a ham in 1961 and has been a long time member of the CCA (#AC94-00030). About 6 years ago Ron and Ruth (XYL - Also a ham) moved to the Texas Hill Country after a lifetime in Arizona. He laments that he is in the process of rebuilding a Collins collection after regrettably (and foolishly) selling his equipment in anticipation of his move. Ron is active on HF and also enjoys DXing, contesting and rag-chewing - including RTTY and PSK31 modes. He also currently works part time as a licensed paramedic for the 911 EMS service in Hays County.



**Karl Bowman, W4CHX**, was elected to replace the outgoing Butch Schartau. Karl is a practicing Veterinarian in the Raleigh, North Carolina area. His wife, Gale, is also a Vet and a ham as well (K4GGB) and they have 3 sons and one grand daughter. Karl was first licensed in 1968, then became active in the 70's and was bitten by the Collins bug in the 90s. Although a relative newcomer to the CCA (#AC09-12404), Karl makes up in enthusiasm what he lacks in years with the group. He and his wife were serious contributors of help and encouragement at the last Dayton event and he has hit the ground running full tilt as a Board Member. I think that Karl set the all time record for soliciting door prizes at last years banquet at Dayton and this year will probably be no different. He is also very active in the Raleigh Amateur Radio Society and find this and his work with the CCA very rewarding. The CCA welcomes both Karl and Ron.

## In the Shack of Dave Meitzen, AA9TT

It is a pleasure to write this since Dave is one of those “behind the scenes” workers and contributors to the CCA that really make things happen in the long run. Dave has been a ham since 1955 (KN5BLD San Antonio) but like many of us, got shanghaied by his career and was inactive for many years. Re-invigorated in 1996, he got his Extra Class (a real one he points out) as AA9TT and immediately started collecting Collins. Certainly the space available here in this issue does not allow the display of his stations as it well deserves.

Educated in Electrical Engineering, Dave has worked in a number of disciplines. He is actually a past Collins R & D employee back in the C Systems days, but now is an entrepreneur and involved in his second Broadband Wireless associated start-up. He has quite a collection of both Collins (and other unmentionables) and tends to be an A-Line and Broadcast (loves his 20V) kind of guy. He also collects parts, literature, or - as he points out - anything Collins that he can afford at the time. So, enjoy what is here, and if you get a chance, go by and try out one of his 19 operating positions. It will be well worth the visit!



## From the President



I have really enjoyed this quarter - as I hope that you have. There has been a lot going on - VERY BUSY - but the two new CCA Board of Directors members, Karl Bowman (W4CHX) and Ron Freeman (K5MM) have really hit the ground running and have been contributing big time. Thank you both so much.

In addition to the normal first of the year activities (election changes, renewals, etc.), we have been really busy with Dayton Hamvention preparation and also the planning of a new event for 2011, which is a CCA get together at Dallas Ham-Com. There is a separate announcement in this issue so I will not dwell on that here, but the Ham-Com team has been very busy and I hope that you all can make this new social and informative event.

I reluctantly have cried uncle - short term - on getting an embroidered clothing offering up on the CCA website. It turns out that there is just a big hurdle to climb, both on our website and on the clothing companies website to make the sites "work" for us and go into "Sales" mode on the CCA site. There has been quite a bit of interest from the membership and we are not giving up - just falling back to regroup.

In the meantime, I have found a great "T" Shirt screening company here in the Wimberley area and I am having some CCA and Collins T shirts made up. We might even do a few Jackets, since this company also does embroidery. I will be taking these shirts, and possibly some jackets, to both the Dayton and the Dallas conventions. The emphasis will be on quality and uniqueness and originality of the artwork, so these should be very interesting. These shirts and jackets, will be made from first class products and use only original Collins artwork.

I would like to take this opportunity to also thank those that are working on the Dayton events and particularly thanks to Jim Stitzinger (WA3CEX) who is again leading the charge on taking care of the planning for Dayton. Jim also is again providing us with some show and tell items with his HF-80 shelter at Dayton, and his infamous Collins S-Line Promo Van at Dallas. BIG thanks Jim. In this time of expensive fuel costs, we know what that means and we appreciate it.

Finally, in spite of some really squirrely propagation, the nets are flourishing and everyone seems to be enjoying themselves. My thanks go out to all of the Net Managers who are making that all

happen and look so effortless. I know that this is not the case and our hats are off to all of you.

See you at one of the events -  
and Best 73s, Bill, N7OTQ

### Call for Articles or In the Shack Photos

*Time to beef up the pending list of articles that I have to work with. For those that have unpublished articles in to me, yes, I do have some.*

*I am particularly looking for writings about older equipment & stories about the Collins folks.*

The **Signal Magazine** is published quarterly by The Collins Collectors Association Copyright© 2011, all rights reserved.

**Editor** Bill Carns, N7OTQ  
**Co-Editor,** Joe Nyberg, W1LJN

#### Board of Directors

Bill Carns, N7OTQ	President
TBD,	Vice Pres.
Jim Stitzinger, WA3CEX,	Secretary
Bill Wheeler, KODEW,	PR
Karl Bowman, W4CHX	Events
Ron Freeman, K5MM	Treasurer

*The CCA is licensed by Rockwell Collins to reproduce and disseminate Collins copyrighted documents related to Collins amateur radio products.*

The Collins Collectors Association  
P.O. Box 1269  
Wimberley, TX 78676-1269

[www.collinsradio.org](http://www.collinsradio.org)

#### Technical Disclaimer

The information contained in this publication is believed to be reliable. However, no responsibility is assumed for inaccuracies or omissions. The CCA, anyone who is a member, and the authors of said material shall not be liable to anyone with respect to liability, loss, or damage caused, or alleged to have been caused, directly or indirectly by this publication or the contents herein.